

Research Activities

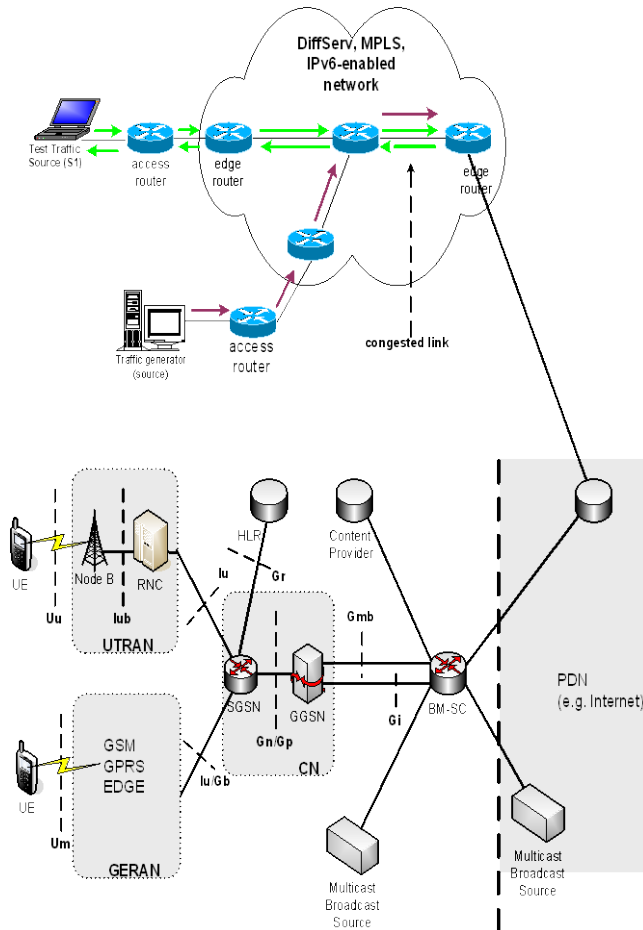

- ❖ IPv6
- ❖ UMTS
- ❖ Quality of Service
- ❖ Metropolitan Area Networks

QoS

During the last years 2 Quality of Service architectures (IntServ and DiffServ) have been proposed and evaluated. Their goal is to provide specific quality (packet loss, delay and jitter) on network traffic

The work of Research Unit 6 on this field focuses on the analytical and experimental evaluation and integration of mechanisms for service differentiation and quality in contemporary high-speed IP-based (v4 and v6) or MPLS based networks. The individual mechanisms available for these purposes are evaluated and extended in the networking level, accompanied by admission control and routing algorithms. Also, analytical design and evaluation of dimensioning algorithm is in our interest.

Additionally, our team works on management systems for QoS services and network. In particular, Bandwidth brokers and semi automated provisioning systems are studied and developed.

Research Unit 6 also works on design and implementation of Managed Bandwidth Service in high speed backbone networks. This takes advantage of features provided by the MPLS technology and also using the DiffServ architecture. It uses Layer 2 MPLS Virtual Private Networks (L2 MPLS VPNs) to provide point to point connections and it also marks the traffic in order to traverse certain priority queues (to provide guaranteed bandwidth). Additionally, it enables traffic engineering characteristics in order to provide load balancing on the network as well as fast rerouting in case of link failure. Our team is also working on the implementation of end-to-end automated provisioning of inter-domain Bandwidth on Demand services using SONET/SDH, Gigabit Ethernet and L2 MPLS VPNs technologies. Finally, Research Unit 6 works on automatic provisioning tools that incorporate all these services.

IPv6

IPv6 is the new Internet Protocol that constitutes an effort to overcome the inborn limitations of IPv4. Along with increasing the address size from 32 to 128 bits, it offers better support for security, authentication, autoconfiguration, extensibility and flexibility in order to cover the new needs as they shape today in the Internet. Additionally, IPv6 uses a new field (Flow label) that can be used for QoS services, providing per flow differentiation.

Research Unit 6 of CTI work in this area focuses on transition mechanisms from IPv4 to IPv6 and on testing QoS mechanisms on IPv6 domains. Also works on application porting (for example OpenH323).

Metropolitan Area Networks

The last years, many countries and municipalities design and implement Metropolitan broadband infrastructure based on optic fibers. Their major characteristics are the open access that means the construction of the networks, should be limited in the construction of infrastructure and equipment that will be open to any telecommunication carrier and service provider. Also, the neutrality of the infrastructure is a key point as the network should be an open access installation to all the organizations that provide electronic networks and services with absolutely no discriminations against them.

Research Unit's 6 work focuses on the design on Metropolitan Area Networks based on open standards and also on the design of the business plan that will be applied and will ensure the network's viability, administration, growth and exploitation of infrastructure.

UMTS

UMTS constitutes the third generation of cellular wireless networks which aims to provide high-speed data access along with real time voice calls. Wireless data is one of the major boosters of wireless communications and one of the main motivations of the next generation standards.

In UMTS, bandwidth is a limited resource, since the available radio resources can support only a handful high data-rate user simultaneously. Multicast is an efficient method of supporting group communication as it allows the transmission of packets to multiple destinations using fewer network resources.

Multicast in UMTS

It is known that multicasting is an efficient method of supporting group communication as it allows the transmission of packets to multiple destinations using fewer network resources. Compared with multicast routing in the Internet, mobile networks such as UMTS pose a very different set of challenges for multicast.

Mobile Internet Access

RU6 works on the field of evaluating the performance of UMTS in different traffic conditions. In this research field, we examine the performance of TCP over UMTS Dedicated Channels (DCH) and the performance of TCP for High Speed Downlink Packet Access (HSDPA) transmissions.

Multimedia over UMTS

The scheme of real time streaming video is one of the newcomers in wireless data communication, raising a number of new requirements in both telecommunication and data communication systems. This scheme is applied when the user experiences real time multimedia content.

UMTS and NS-2 Network Simulator

NS-2 is a discrete event simulator targeted at networking research. RU6 uses it for the research work. NS-2 does not include the implementation of the UMTS architecture. However, in our work, we use the Eurane extension, which supports the UMTS architecture. The above proposed mechanisms are implemented in the NS-2 for the evaluation of their performance.

CONTACT INFORMATION

RESEARCH UNIT 6

University Campus, Building B', GR-26500 Patras, Greece

Tel.: (+30) 2610 960375, 2610 960355
2610 960380, 2610 960316

Fax: (+30) 2610 960358

URL: <http://ru6.cti.gr/>

E-mail: rd-unit-6@cti.gr

CONTACT PERSON

Christos Bouras (Professor)

Tel: (+30) 2610 960375

Fax: (+30) 2610 969016

URL: <http://ru6.cti.gr/bouras/>

E-mail: bouras@cti.gr

COMPUTER TECHNOLOGY INSTITUTE & PRESS “DIOPHANTUS”

RESEARCH UNIT 6

NETWORKS, TELEMATICS AND NEW SERVICES

Research Field:

Networking technologies



COMPUTER TECHNOLOGY
INSTITUTE & PRESS
“DIOPHANTUS”

