

Performance Evaluation of LTE for MBSFN Transmissions

Antonios Alexiou
Computer Engineering and Informatics
Department
University of Patras
Patras, Greece
alexiaua@ceid.upatras.gr

Christos Bouras, Vasileios Kokkinos, George Tsichritzis
Research Academic Computer Technology Institute and
Computer Engineering and Informatics Department
University of Patras
Patras, Greece
bouras@cti.gr, kokkinos@cti.gr, tsixritzis@cti.gr

Contact Person:

Christos Bouras

Research Academic Computer Technology Institute, N. Kazantzaki str, GR-26500 Patras, Greece; and
Computer Engineering and Informatics Dept., Univ. of Patras, GR-26500 Patras, Greece

Tel:+30-2610-960375

Fax:+30-2610-969016

e-mail: bouras@cti.gr

Abstract:

Long Term Evolution (LTE) is the most promised latest step towards the 4th generation (4G) of radio technologies designed to increase the capacity and speed of mobile communications with main target the support of the so-called “Mobile Broadband”. To support Multimedia Broadcast/Multicast Services (MBMS), LTE offers the possibility to transmit Multimedia Broadcast multicast service over a Single Frequency Network (MBSFN), where a time-synchronized common waveform is transmitted from multiple cells for a given duration. In this manuscript we analytically present the MBSFN delivery method and evaluate its performance. The critical parameters of primary interest for the evaluation of the scheme are the packet delivery cost and its scalability. To this direction, a telecommunication cost analysis of the MBMS service is presented based on the transmission cost over the air interface, as well as the costs of all interfaces and nodes of the MBSFN architecture. Based on this cost analysis we determine the ideal number of cells that should participate in the MBSFN transmission in order to improve the overall MBSFN performance. Since the performance of the MBSFN scheme mainly depends on the configuration of the LTE network that is under investigation, we consider different network topologies, MBSFN deployments and user distributions.

Performance Evaluation of LTE for MBSFN Transmissions

Antonios Alexiou
Computer Engineering and Informatics
Department
University of Patras
Patras, Greece
alexiaa@ceid.upatras.gr

Christos Bouras, Vasileios Kokkinos, George Tsichritzis
Research Academic Computer Technology Institute and
Computer Engineering and Informatics Department
University of Patras
Patras, Greece
bouras@cti.gr, kokkinos@cti.gr, tsixritzis@cti.gr

Abstract—Long Term Evolution (LTE) is the most promised latest step towards the 4th generation (4G) of radio technologies designed to increase the capacity and speed of mobile communications with main target the support of the so-called “Mobile Broadband”. To support Multimedia Broadcast/Multicast Services (MBMS), LTE offers the possibility to transmit Multimedia Broadcast multicast service over a Single Frequency Network (MBSFN), where a time-synchronized common waveform is transmitted from multiple cells for a given duration. In this manuscript we analytically present the MBSFN delivery method and evaluate its performance. The critical parameters of primary interest for the evaluation of the scheme are the packet delivery cost and its scalability. To this direction, a telecommunication cost analysis of the MBMS service is presented based on the transmission cost over the air interface, as well as the costs of all interfaces and nodes of the MBSFN architecture. Based on this cost analysis we determine the ideal number of cells that should participate in the MBSFN transmission in order to improve the overall MBSFN performance. Since the performance of the MBSFN scheme mainly depends on the configuration of the LTE network that is under investigation, we consider different network topologies, MBSFN deployments and user distributions.

Keywords-LTE, MBSFN, cost analysis, e-MBMS

I. INTRODUCTION

Long Term Evolution (LTE) is focused on enhancing the Universal Terrestrial Radio Access (UTRA) and optimizing 3GPP's (3rd Generation Partnership Project) radio access architecture. LTE supports scalable carrier bandwidths, from 20 MHz down to 1.4 MHz and provides downlink peak rates of at least 100 Mbps, an uplink of at least 50Mbps and round-trip times of less than 10 ms. Orthogonal Frequency Division Multiplexing (OFDM) has been selected for the downlink and Single Carrier-Frequency Division Multiple Access (SC-FDMA) for the uplink.

The 3GPP has introduced Multimedia Broadcast/Multicast Service (MBMS) as a mean to broadcast and multicast information to 3G and 4G users. MBMS is an efficient method for delivering multimedia content to multiple destinations, by allowing resources to be shared in an economical way [1], [2].

In the context of the "Long Term Evolution" of 3G systems the MBMS will evolve into the e-MBMS [3] ("e-" stands for evolved). The LTE e-MBMS aims at providing broadcast and multicast services combining flexibility and high efficiency in the spectrum occupancy. This will be achieved through increased performance of the air interface that will include a new transmission scheme called Multimedia Broadcast multicast service over a Single Frequency Network (MBSFN).

In MBSFN operation, MBMS data is transmitted simultaneously over the air from multiple tightly time-synchronized cells. A group of those cells which are targeted to receive the broadcast MBSFN data constitute a so called MBSFN area. All cells within an MBSFN area contribute to the MBSFN transmission and advertise its availability. A User Equipment (UE) receiver will therefore observe multiple versions of the signal with different delays due to the multicell transmission. In effect, this makes the MBSFN transmission, as seen by the UE, a transmission to a single large cell, and the UE receiver may treat the multicell transmissions in the same way as multipath components of a single-cell

transmission without incurring any additional complexity. The UE does not even need to know how many cells are transmitting the signal.

The MBSFN transmission mode leads to significant improvements in spectral efficiency compared to Universal Mobile Telecommunications System (UMTS) MBMS, since the MBSFN transmission greatly enhances the Signal to Interference-plus-Noise Ratio (SINR). This is extremely beneficial at the cell edge, where transmissions (which in UMTS are considered as inter-cell interference) are translated into useful signal energy and hence the received signal strength is increased while, at the same time the interference power is largely reduced [4]. In general MBSFN offers better performance compared to classic single cell point-to-point (PTP) or point-to-multipoint (PTM) transmissions [5]. Moreover, the MBSFN performance depends on the number of cells transmitting the MBSFN service. Specifically, it has been proven that the MBSFN service performance in the air interface increases drastically when apart from the cells that contain users, neighboring cells assist in the MBSFN transmission as well [6].

In this manuscript we evaluate the MBSFN delivery scheme in terms of packet delivery cost, cost for control procedures (synchronization, polling) and scalability of the scheme. Furthermore, since the performance of this scheme depends mainly on the configuration of the LTE network that is under investigation, we consider different network topologies, MBSFN deployments and user distributions. Based on these parameters, we calculate the total cost required for the transmission of the MBSFN data to mobile users of a given MBSFN service. To our knowledge an end-to-end cost based evaluation approach of the MBSFN transmission has not yet been studied and it is our belief that this approach could conclude to more sophisticated simulation results than focusing only on the spectral efficiency in the air interface. Finally, we estimate how many neighboring cell rings should be included in the same MBSFN area and thus transmit in the same frequency with the cells that actually contain users so as to achieve high SFN gains with the lowest possible telecommunication cost with respect to users' distribution in the topology.

The manuscript is structured as follows: Section II presents the related work in the specific field, while, an overview of MBSFN architecture is presented in Section III. The telecommunication cost analysis of the MBSFN delivery scheme is described in Section IV and in Section V we analyze the evaluation results of our approach. Finally, the planned next steps and the concluding remarks are briefly described in sections VI and VII respectively, while a list of the abbreviations used in the manuscript with their explanation can be found in Appendix A at the end of the document.

II. RELATED WORK

The performance of MBSFN has been thoroughly examined in previous research works. However, most of these works compare the performance of MBSFN transmissions with classic PTP and PTM transmissions, in which the users are served with PTP or PTM transport channels respectively and the transmissions are executed in a per-cell basis without examining the region that the users are found as a whole entity. More specifically, research work [6] compares the PTP and PTM provisioning of an MBMS service (in a per-cell basis) and the MBMS transmission with MBSFN (multi-cell). The three different modes are evaluated by comparing the spectral efficiency of each mode for different user distributions in a topology and as conclusion the superiority of the MBSFN transmission mode is proved. The research work [7], where the mean fraction of resources (time share) is used for the evaluation of each transmission mode, leads to similar results. Moreover, research work [5] evaluates which technique is more efficient for different user densities in a cell and concludes that MBSFN is the most efficient mode for normal and high user densities. To sum up, all the above research works conclude that MBSFN is the most efficient method for the delivery of MBMS data, which in turn led to the standardization of the MBSFN for MBMS transmissions [3]. Therefore, in this manuscript we only focus on MBSFN transmissions and we propose a novel approach that could further improve the MBSFN performance.

Moreover, research work [6] examines how many neighboring cell rings should be included in the same MBSFN area with the cells that actually contain users. These neighboring cell rings are called assisting rings and actually transmit in the same frequency with the cells that contain users so as to improve the overall MBSFN performance. In order to estimate the ideal number of assisting rings, work [6] takes into account only the air interface cost in terms of spectral efficiency and not the total telecommunication cost which also includes the costs of the core network in order. To our knowledge an end-to-end cost based evaluation approach of the MBSFN transmission has not yet been studied and it is our belief that this approach could conclude to more sophisticated simulation results than focusing only on the spectral efficiency in the air interface.

On the other hand, an end-to-end cost analysis model for the evaluation of different one-to-many packet delivery schemes in UMTS is presented in research works [8] and [9]. In these works, the authors consider different transport channels for the transmission of the MBMS data over the UMTS interfaces. However, both these approaches focus on UMTS networks and cannot be applied in next generation LTE networks. In this manuscript we extend the above research works by evaluating the MBSFN delivery scheme and the total telecommunication cost required for the transmission of the MBMS data to mobile users. Moreover, we improve the overall MBSFN performance by estimating the appropriate number of assisting rings in order to achieve high SFN gains with the lowest possible cost with respect to users' distribution in the topology.

III. OVERVIEW OF E-MBMS LTE ARCHITECTURE

The e-MBMS architecture is illustrated in Figure 1. As illustrated in Figure 1, the MBSFN architecture is split into three main domains: the UE domain, the e-UTRAN (evolved UTRA Network) and the Evolved Packet Core (EPC). The UE domain consists of the equipment employed by the user to access the MBSFN services. Within e-UTRAN, the e-NBs (evolved Node B or base station) are the collectors of

the information that has to be transmitted to users over the air-interface. The MCEs (Multi-cell/multicast Coordination Entity) coordinate the transmission of synchronized signals from different cells (e-NBs) and are responsible for the allocation of the same radio resources, used by all e-NBs in the MBSFN area for multi-cell MBMS transmissions. Moreover, MCE is responsible for the radio configuration e.g. selection of modulation and coding scheme.

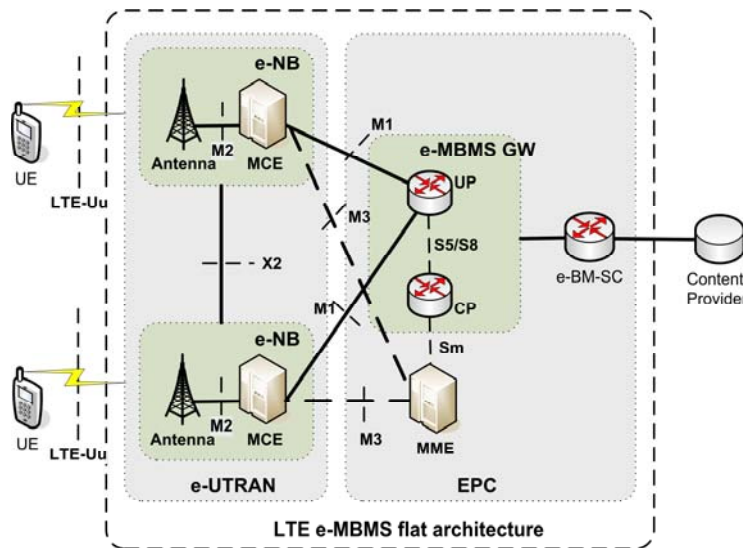

Figure 1. LTE e-MBMS flat architecture [3].

The EPC consists of three nodes, the e-MBMS Gateway (e-MBMS GW), the evolved Broadcast Multicast Service Center (e-BM-SC) and the Mobility Management Entity (MME). The e-MBMS GW is physically located between the e-BM-SC and e-NBs and its principal functionality is to forward the MBMS packets to each e-NB transmitting the service. Furthermore, e-MBMS GW performs MBMS Session Control Signaling (Session start/stop) towards the e-UTRAN via the MME. The e-MBMS GW is logically split into two domains. The first one is related to control plane, while the other one is related to user plane. Likewise, two distinct interfaces have been defined between e-MBMS GW and e-UTRAN namely M1 for user plane and M3 for control plane (via the MME node). M1 interface makes use of IP

Regarding the air (or LTE-Uu) interface, MBSFN uses two logical channels (in downlink), namely Multicast Traffic Channel (MTCH) and Multicast Control Channel (MCCH). MTCH is a PTM downlink channel for transmitting data traffic to the UEs residing to the service area. On the other hand, MCCH is a PTM downlink channel used for transmitting MBMS control information from the network to UEs and is associated to one or several MTCHs. MCCH and MTCH are only used by UEs that receive MBMS traffic. Additionally, both MCCH and MTCH are mapped on the Multicast Channel (MCH) which is a transport channel at the Medium Access Control (MAC) layer. MCH is a broadcast channel that supports semi-static resource allocation e.g. with a time frame of a long Cyclic Prefix (CP). MCH is mapped to the Physical Multicast Channel of the physical layer [3], [10].

IV. COST ANALYSIS OF MBSFN

In this section, we present a performance evaluation of MBSFN delivery scheme. For our analysis, we assume different network topologies, user distributions and MBSFN deployments during the evaluation.

As the performance metric for the evaluation, we consider the total telecommunication cost for both packet deliveries and control signals transmissions [11]. In our analysis, the cost for MBSFN polling is differentiated from the cost for packet deliveries. Furthermore, we make a further distinction between the processing costs at nodes and the transmission costs on links in accordance with [11]. For the analysis, we apply the following notations:

| | |
|----------------|---|
| D_{Uu} | Transmission cost of single packet delivery over Uu interface |
| D_{M1} | Transmission cost of single packet delivery over M1 interface |
| D_{p_eNB} | Cost of polling procedure at each e-NB |
| D_{M2} | Transmission cost of single packet delivery over M2 interface |
| N_p | Total number of packets of the MBSFN session |
| N_{eNB} | Number of e-NBs that participate in MBSFN |
| N_{cell} | Total number of e-NBs in the topology |
| N_{p_burst} | Mean number of packets transmitted in each packet burst |
| C_{Uu} | Total cost over Uu interface |
| C_{M1} | Total cost over M1 interface |
| C_{SYNC} | Processing cost for synchronization at e-BM-SC |
| $C_{Polling}$ | Processing cost for polling |
| C_{MBSFN} | Total telecommunication cost of the MBSFN transmission |

Before presenting in detail the above parameters, some general assumptions of our analysis and the topology under examination are presented.

A. General Assumptions and Topology

We assume that the topology is scalable and has the possibility to consist of an infinite number of cells according to Figure 2. Moreover, in order to calculate the total cost, we assume that the users can be located in a constantly increasing area of cells in the topology, called “UE drop location cells”. Therefore, in the case when the number of UE drop location cells is equal to 1, all users are located in the center cell (see Figure 2). The six cells around the center cell constitute the inner 1 ring. Likewise, the inner 2 ring consists of the 12 cells around the first ring. Following this reasoning we can define the “inner 3 ring”, the “inner 4 ring” etc. In this manuscript the following user distributions are examined:

- All MBSFN users reside in the center cell (UE drop location cells = 1).
- All MBSFN users reside in the area included by the inner 1 ring (UE drop location cells = 7).

- All MBSFN users reside in the area included by the inner 2 ring (UE drop location cells = 19).
- ...
- All the infinite cells of the topology contain users interested in a MBSFN service (UE drop location cells = infinite, i.e. number of cells $\gg 721$ or number of cell rings $\gg 15$).

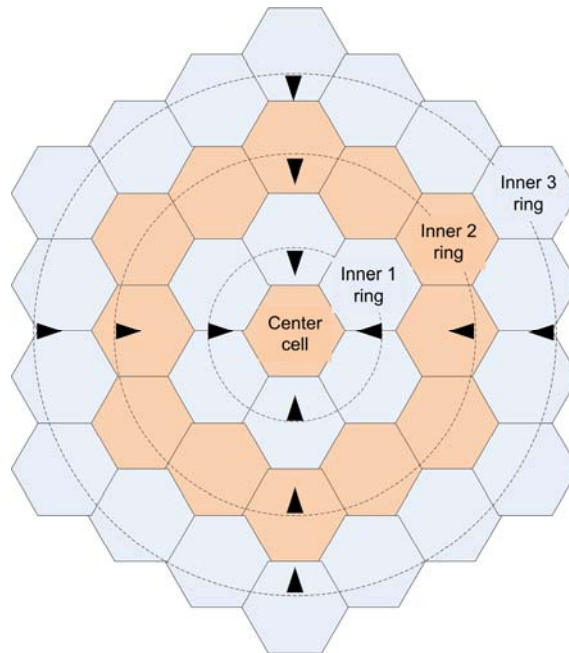

Figure 2. Topology under examination.

The performance of the MBSFN increases rapidly when rings of neighboring cells outside the “UE drop location cells” area assist the MBSFN service and transmit the same MBSFN data. More specifically according to [6] and [12], even the presence of one assisting ring can significantly increase the overall spectral efficiency. Moreover, we assume that a maximum of 3 neighboring rings outside the “UE drop location cells” can transmit in the same frequency and broadcast the same MBSFN data (assisting rings), since additional rings do not offer any significant additional gain in the MBSFN transmission [6], [12]. Our goal is to examine the number of neighboring rings that should be transmitting

- **AII**: The first ring around the UE drop location cells, contributes in the MBSFN transmission, the second and third rings act as interference.
- **AAI**: The first and the second ring around the UE drop location cells assist in the MBSFN transmission, the third ring acts as interference.
- **AAA**: indicates that each of the 3 surrounding rings of the UE drop location cells assists in the MBSFN transmission.

Depending on the number of the UE drop location cells, our target is to find which MBSFN deployment (AII, AAI, AAA) is more efficient in terms of overall cost. For comparison reasons we have also included the **III** deployment, where the 3 surrounding rings of the UE drop location cells do not assist in the MBSFN transmission but act as interference.

The system simulation parameters that were taken into account for our simulations are presented in Table 1. The typical evaluation scenarios used for LTE are macro Case 1 and macro Case 3 with 10 MHz bandwidth and low UE mobility. The propagation models for macro cell scenario are based on the Okamura-Hata model [4], [6]. Moreover, Table 1 presents the chosen values for the simulation parameters, such as the number of packets, the number of hops between the nodes connected by M1 and M2 interface (l_{M1} and l_{M2} respectively), the profile of the M1 and M2 interfaces in terms of link capacity (k_{M1} and k_{M2} respectively). The values for these parameters are in accordance to [13].

Table 1. Simulation parameters.

| Parameter | Units | Case 1 | Case 3 |
|---------------------------|-------|--|--------|
| Inter Site Distance (ISD) | m | 500 | 1732 |
| Carrier Frequency | MHz | 2000 | |
| Bandwidth | MHz | 10 | |
| Penetration Loss (PL) | dB | 20 | |
| Path Loss | dB | Okumura-Hata | |
| Cell Layout | | Hexagonal grid, 3 sectors per site, Infinity rings | |
| Channel Model | | 3GPP Typical Urban (TU) | |
| # UE Rx Antennas | | 2 | |
| UE speed | Km/h | 3 | |
| BS transmit power | dBm | 46 | |
| BS # Antennas | | 1 | |
| BS Ant. Gain | dBi | 14 | |
| N_p | | 10000 | |
| N_{p_burst} | | $N_p / 100$ | |
| k_{M1} | | 0.5 | |
| l_{M1} | | 3 | |
| k_{M2} | | 0.5 | |
| l_{M2} | | 1 | |

B. Air Interface Cost

In this section the transmission cost over the air interface is defined for different network topologies, user distributions and MBSFN deployments. In general, the air interface cost depends on the resource efficiency of SFN transmission mode (i.e., the spectral efficiency of the SFN transmission normalized by the fraction of cells in the SFN area containing UEs) and therefore on the measured SINR so as a certain Block Error Rate (BLER) target to be achieved. For the calculation of the SINR we assume that the

$$SINR(m) = \frac{\sum_{i=1}^N \sum_{j=1}^M \frac{w(\tau_i(m) + \delta_j) P_j}{q_i(m)}}{\sum_{i=1}^N \sum_{j=1}^M \frac{(1 - w(\tau_i(m) + \delta_j)) P_j}{q_i(m)} + N_0} \quad (1)$$

with:

$$w(\tau) = \begin{cases} 1 & 0 \leq \tau < T_{CP} \\ 1 - \frac{\tau - T_{CP}}{T_u} & T_{CP} \leq \tau < T_{CP} + T_u \\ 0 & otherwise \end{cases} \quad (2)$$

where P_j is the average power associated with the j path, $\tau_i(m)$ the propagation delay from base station i , δ_j the additional delay added by path j , $q_i(m)$ the path loss from base station i , T_{cp} the length of the CP and T_u the length of the useful signal frame.

In order to estimate the achieved throughput, (3) is used. In (3), BW is the total bandwidth offered by LTE, $e(SINR)$ is the effective code rate of the selected modulation scheme and $BLER(SINR)$ the block error rate [14].

$$Throughput = BW \cdot e(SINR) \cdot (1 - BLER(SINR)) \quad (3)$$

Finally, the formula from which the spectral efficiency and therefore the resource efficiency can be obtained is:

$$Spectral_Efficiency = \frac{Throughput}{BW} \quad (4)$$

In our analysis and in accordance to [6], the resource efficiency is calculated at the 95% coverage of the MBSFN area. Based on the above, Figure 3 depicts the resource efficiency of SFN transmission mode as the number of UE drop location cells increases, for the 3 different MBSFN deployments (AII, AAI, AAA) presented in the previous paragraph. More specifically, Figure 3(a) presents the way the resource efficiency changes with the number of UE drop location cells for a macrocellular Case 1 environment and Figure 3(b) for a macrocellular Case 3 environment [6].

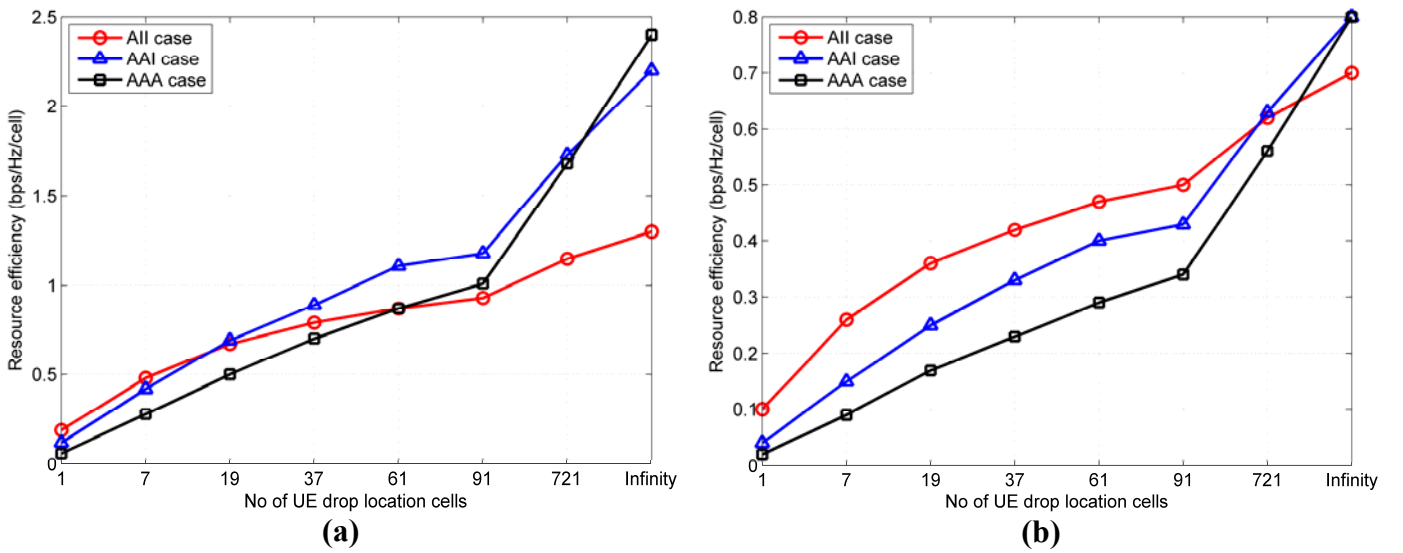

Figure 3. Resource efficiency vs. number of UE drop location cells for: (a) ISD = 500m (macro Case 1), (b) ISD = 1732m (macro Case 3).

From Figure 3(a), we observe that when all users are distributed in the center cell, the resource efficiency for AAA is 0.06, for AAI 0.12 and for AII 0.19. As a result, when all the MBSFN users reside in the center cell, AII is the best deployment. Similarly, if the number of UE drop location cells is equal to 19, the resource efficiency for AAA deployment is 0.5, for AAI 0.69 and finally for AII 0.67. Hence, for this case, AAI is the best deployment in terms of resource efficiency. However, we have to mention that in the above mentioned examples; the best deployment was selected based only on the air interface

performance. Next in our analysis, we will present an alternative/improved approach that selects the best MBSFN deployment based on the overall telecommunication cost.

Similar results can be extracted from Figure 3(b) that corresponds to the macro Case 3. If we compare the resource efficiency performance between Case 1 and Case 3, we observe that Case 1 achieves higher resource efficiency than Case 3. This is explained from the fact that the ISD in Case 1 is smaller than in Case 3 and therefore, from (1) the SINR of Case 1 is greater than the SINR of Case 3. In other words, a large ISD (Case 3) results in increasing the propagation delay and in turn, results in a lower value of SINR and in a lower value of resource efficiency.

To define the telecommunication cost over the air interface, we used the resource efficiency from Figure 3. From Figure 3 we observe that the maximum resource efficiency is 2.40 for macro Case 1 and 0.8 for macro Case 3. These maximum values appear when the users are located in an infinite ring topology (number of cells $\gg 721$ or number of cell rings $\gg 15$). In our analysis, we define as resource efficiency percentage ($RE_percentage$) the fraction of current deployment resource efficiency to the maximum SFN resource efficiency.

$$RE_percentage = \frac{\text{Resource efficiency of current deployment}}{\text{Max SFN resource efficiency}} \quad (5)$$

The percentage indicates the quality of the resource efficiency our current deployment achieves for the macrocellular Case 1 or Case 3, compared to the maximum resource efficiency that can be achieved in Case 1 or Case 3 respectively.

Then, we define the cost of a single packet delivery over the air interface (D_{Uu}) as follows:

$$D_{Uu} = \frac{1}{RE_percentage} \quad (6)$$

This means that as the resource efficiency of a cell increases, the *RE_percentage* increases too, which in turn means that the cost of packet delivery over the air interface decreases. On the other hand, if the resource efficiency of a cell decreases the equivalent transmission cost increases. Therefore, if a deployment X has worse spectral efficiency than a deployment Y, this means that a higher transmission cost for packet delivery should be defined for deployment X than in Y.

From the above analysis, it is derived that the total cost for all e-NBs (N_{eNB}) in a MBSFN area to transmit N_p packets over the corresponding Uu interfaces is given by the following equation:

$$C_{Uu} = D_{Uu} \cdot N_p \cdot N_{eNB} \quad (7)$$

C. Cost over M1 Interface

M1 interface uses IP multicast protocol for the delivery of packets to e-NBs. In multicast, the e-MBMS GW forwards a single copy of each multicast packet to those e-NBs that participate in MBSFN transmission. After the correct multicast packet reception at the e-NBs that serve multicast users, the e-NBs transmit the multicast packets to the multicast users via MTCH transport channels. The total telecommunication cost for the transmission of the data packets over M1 interface is derived from (8), where N_{eNB} represents the number of e-NBs that participate in MBSFN transmission, N_p the total number of packets of the MBSFN session, and D_{M1} is the cost of the delivery of a single packet over the M1 interface.

$$C_{M1} = N_p \cdot D_{M1} \cdot N_{eNB} \quad (8)$$

The cost of the delivery of a single packet over the M1 interface is given by (9) [13]:

$$D_{M1} = \frac{l_{M1}}{k_{M1}} \quad (9)$$

where l_{M1} is the number of hops between the nodes connected by M1 interface and k_{M1} represents the profile of the M1 interface in terms of link capacity [13]. In general, a higher link capacity in M1 results in a higher value of k_{M1} . According to (9), a high value of k_{M1} corresponds to a low packet delivery cost over M1 and a small number of hops corresponds to a low packet delivery cost as well.

D. Synchronization Cost

In order to implement an SFN, each of the transmitting cells should be tightly time-synchronized and use the same time-frequency resources for transmitting the bit-identical content. Thus, SFN operation employs content synchronization of the base stations transmitting an MBMS within, for instance, an associated deployment area. The overall user plane architecture for content synchronization is depicted in Figure 4.

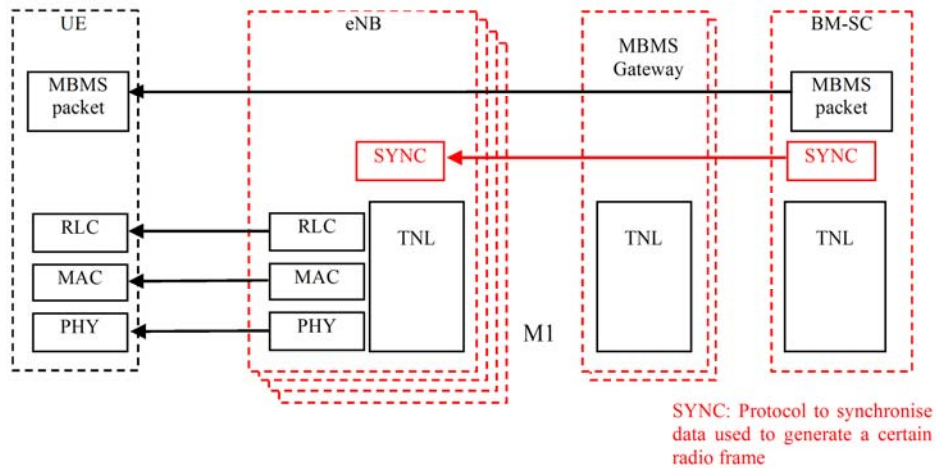

Figure 4. Content synchronization in MBSFN.

The SYNC protocol layer is defined on transport network layer to support content synchronization. It carries additional information that enables e-NBs to identify the timing for radio frame transmission and detect packet loss. Every e-MBMS service uses its own SYNC entity. The SYNC protocol operates

The e-BM-SC should indicate the timestamp (T) of the transmission of the first packet of a burst of data (block of packets) by all e-NBs and the interval between the radio transmissions of the subsequent packets of the burst as well. Since the synchronization protocol has not yet been standardized and many alternative protocols have been proposed [15], we assume that the transmission timestamp of the first packet of a burst of data is sent before the actual burst in a separate Packet Data Unit (PDU). When time T is reached, the e-NB buffer receives another value of T and new packet data, which correspond to the next burst. All in all, in this case the transmission timing for subsequent bursts is implicitly determined by the size and the number of previous packets [15]. This in turn means that the synchronization cost depends on the total numbers of multicast bursts/packets per MBSFN session. The total telecommunication cost for the transmission of the synchronization packets is derived from the following equation, where N_{eNB} represents the number of e-NBs that participate in the MBSFN transmission, N_p the total number of packets of the MBSFN session, D_{M1} is the cost of the delivery of a single packet over the M1 interface and N_{p_burst} is the mean value of the number of packets transmitted each time in the sequential bursts of the MBSFN session.

$$C_{SYNC} = \frac{N_p}{N_{p_burst}} \cdot D_{M1} \cdot N_{eNB} \quad (10)$$

By combining (8) and (10), the following equation can be extracted:

$$C_{SYNC} = \frac{C_{M1}}{N_{p_burst}} \quad (11)$$

E. Polling Cost

To determine which cells contain users interested in receiving a MBSFN service, we assume that a polling procedure is taking place. In contrast to counting procedure used in UMTS MBMS, where the exact number of MBMS users was determined, with polling we just determine if the cell contain at least one user interested for the given service.

The e-NBs initiate the detection procedure by sending a UE feedback request message on MCCH. The cost of sending this request message corresponds to the cost of polling procedure at e-NB (D_{p_eNB}). The message includes the MBMS service ID that requires the user feedback and a “dedicated access information” (in the form of a particular signature sequence) that is to be used for the user feedback by the UEs. After receiving the feedback request message, the UEs, which are interested in receiving the particular MBMS service, respond to the request by sending a feedback message using the allocated “dedicated access resources” over non-synchronous Random Access Channel (RACH).

The e-NB receives the feedback from the UEs in the form of signature sequence. If energy is detected corresponding to the known signature sequence, this indicates that at least one user in the coverage area of the e-NB is interested in or activated the particular MBMS service. This information (packet) is sent to the MCE over M2 interface, which in turn estimates which cells contain MBMS users interested for the given MBMS service [16].

The total cost associated to the polling procedure is derived from (12), where N_{cell} is the total number of e-NBs in the topology (since all e-NBs send a UE feedback request message), N_{eNB} represents the number of e-NBs that participate in MBSFN transmission, D_{p_eNB} the cost of polling procedure at each e-NB (equal to D_{Uu}) and D_{M2} is the cost of the delivery of a single packet over the M2 interface.

$$C_{Polling} = C_{Polling_air} + C_{Polling_core} = D_{p_eNB} \cdot N_{cell} + D_{M2} \cdot N_{eNB} \quad (12)$$

F. Total Telecommunication Cost

Based on the analysis presented in the previous paragraphs, the total telecommunication cost of the MBSFN delivery scheme is derived from the following equation.

$$\begin{aligned}
 C_{MBSFN} &= k_{air} \cdot (C_{Uu} + C_{Polling_air}) + k_{core} \cdot (C_{M1} + C_{SYNC} + C_{Polling_core}) = \\
 &= k_{air} \cdot (D_{Uu} \cdot N_p \cdot N_{eNB} + D_{p_eNB} \cdot N_{cell}) + k_{core} \cdot \left[D_{M1} \cdot N_p \cdot N_{eNB} + \frac{D_{M1}}{N_{p_burst}} \cdot N_p \cdot N_{eNB} + D_{M2} \cdot N_{eNB} \right] \quad (13)
 \end{aligned}$$

where k_{air} is the weight of the air interface cost and k_{core} the weight of the core interface cost (where: $k_{air} + k_{core} = 1$). One of the most significant operational expenses in LTE networks is the transmission cost between the nodes and interfaces of the core network (or EPC). Moreover, the fact that the capacity of the core network interfaces is limited indicates that these interfaces should be included in our analysis. In our analysis we have considered different values for the weights k_{air} and k_{core} . More specifically, after taking into account that the air interface is the most critical interface in mobile networks, we consider the following three values for k_{air} : 0.7, 0.8 and 0.9. Therefore, the weight for the core interface cost is set to 0.3, 0.2 and 0.1 respectively. The actual value of the air interface weight will be determined by the operator / content provider.

V. RESULTS

Having analyzed the costs of the MBSFN delivery scheme, we try to evaluate the cost of each of the MBSFN deployments (AAA, AAI, AII) for different user distributions. In order to better reveal that the performance of the MBSFN increases when rings of neighboring cells outside the ‘‘UE drop location cells’’ area assist the MBSFN service, in the figures that follow we have included the III deployment, where none of the 3 surrounding rings assist in the MBSFN transmission. The topology we used is the one described in Section IV.A.

Figure 5, depicts the normalized total cost of the deployments AII, AAI, AAA and III as the number of packets of the MBSFN service increases from 0 to 10000 in a macro Case 1 environment when air interface weight $k_{air} = 0.9$. More specifically, Figure 5(a) refers to the case where the number of UE drop location cells is 7. For this case we observe that as the number of packets increases, the total cost increases as well. This increment is mainly caused by the simultaneous increment of the air interface cost. We also observe that AII is the most efficient deployment for transmission in terms of total cost since it results in the lowest total cost. On the other hand, Figure 5(b) depicts the total cost of AAA, AAI, AII and III when the number of UE drop location cells is 91. For this case, we observe that AAI is the most efficient deployment, while III results in an abrupt increase in the total cost and therefore constitutes the most cost-expensive deployment for the delivery of the MBSFN data.

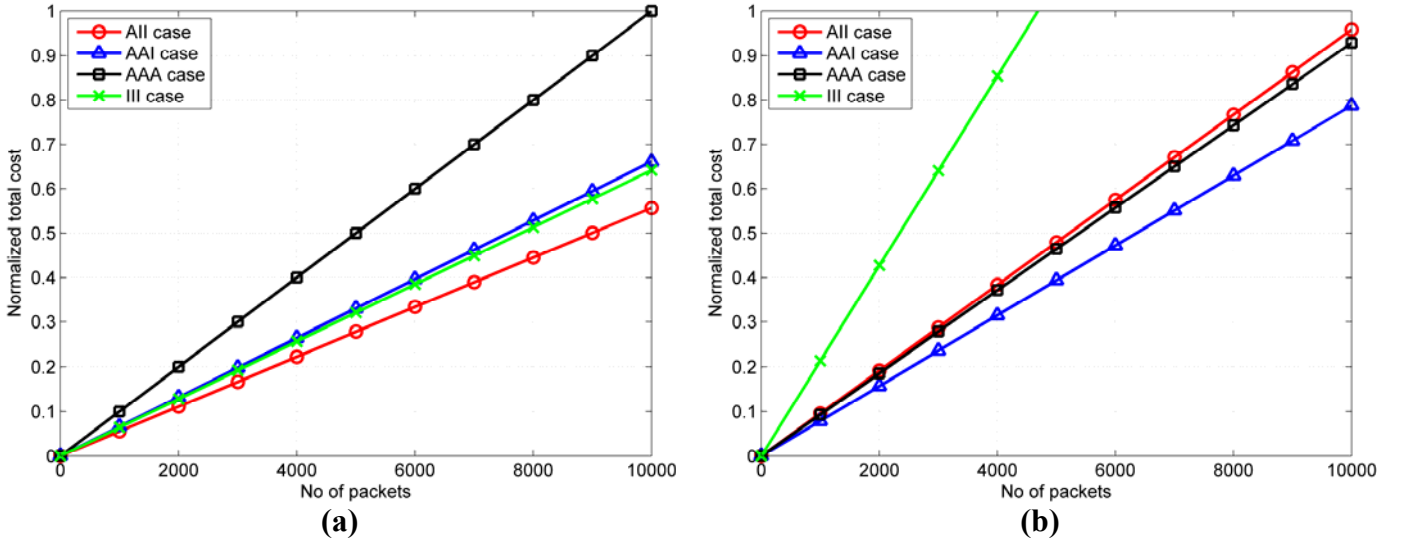

Figure 5. MBSFN cost for AII, AAI, AAA vs. number of packets for macro Case 1 when $k_{air} = 0.9$ and (a) UE drop location cells = 7, (b) UE drop location cells = 91.

Based on the above, it is clear that the way the users are distributed in the topology has a great impact on the selection of the most cost efficient MBSFN deployment. This observation leads us to determine

the appropriate switching points (number of UE drop location cells) between the different deployments for various values of air interface weight k_{air} and different macrocellular cases.

More specifically, Figure 6(a) depicts the total cost of the SFN transmission for the 3 different deployments (AII, AAI, AAA) as the number of UE drop location cells increases, when $ISD = 500m$ (macro Case 1) and $k_{air} = 0.9$. Deployment III is also depicted in Figure 6(a) for comparison reasons. We observe that for the first 3 user distributions (cases of 1, 7, 19 UE drop location cells), AII deployment ensures the lowest cost for the delivery of the MBSFN data. On the other hand, for UE drop location cells 37, 61, 91 and 721 cells, AAI is the most cost efficient deployment. Finally, for the case of the MBSFN transmission where the users are residing in infinite cells, the AAA deployment is more efficient than the other deployments, since it results in a lower overall cost. Irrespectively of the number of the UE drop location cells, III deployment cannot guarantee the lowest cost. Therefore, it is clear that even the presence of one assisting ring can significantly increase the MBSFN performance.

Generally, it is necessary to switch between the different deployments, when the number of UE drop location cells increases, so as to achieve the lowest possible transmission cost. More specifically, in Figure 6(a) as the number of UE drop location cells increases, the most efficient deployment for the delivery of the MBSFN data, switches from AII, to AAI and finally to AAA when the number of cells that have users interested in the MBSFN service approaches infinity (number of cells $\gg 721$). This switching can save resources both in the core network and the air interface. For example, in the case of 721 UE drop location cells, we observe that the normalized total cost is 0.6967 when AII is used, 0.4879 when AAI is used, 0.5077 when AAA is used and finally, 1.8958 when III is used (the costs have been normalized to the maximum cost of AII, AAI and AAA deployment). Therefore, the usage of AAI can decrease the total telecommunication cost by $(0.6967-0.4879) / 0.6967 = 29.96\%$ compared to AII

deployment, $(0.5077-0.4879) / 0.5077 = 3.9\%$ compared to AAA deployment and $(1.8958-0.4879) / 1.8958 = 74.26\%$ compared to III deployment.

Additionally, Figure 6(b) depicts the total cost of the SFN transmissions of the four different deployments (AII, AAI, AAA and III) for the different user distributions when $ISD = 1732m$ (macro Case 3). We observe that for the first 6 user distributions (UE drop location cells = 1, 7, 19, 37, 61 and 91) the most efficient MBSFB deployment is AII. For UE drop location cells equal to 721 and for infinite UE drop location cells ($\gg 721$), AAI is the most efficient deployment and should be preferred over the other MBSFN deployments. The total cost of III deployment remains in relatively low values for the first 6 user distributions; however it never ensures the lowest cost. Moreover, when the number of UE drop location cells increases (721 and infinite cells) the total cost of III increases in unacceptable high levels.

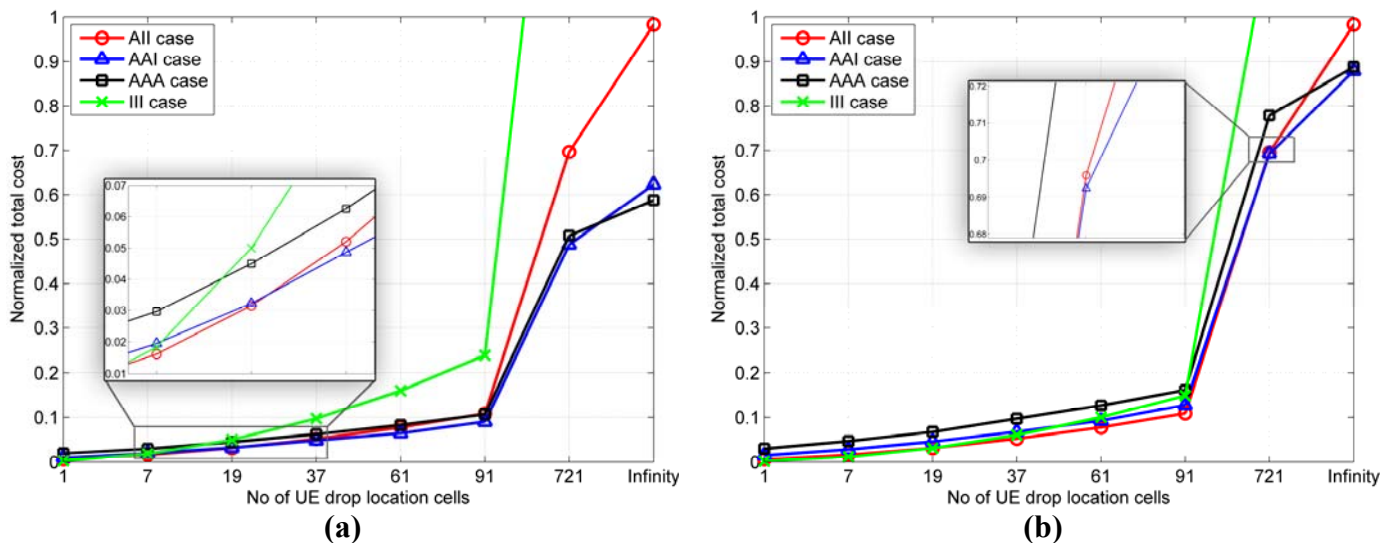

Figure 6. MBSFN cost for AII, AAI, AAA vs. number of UE drop location cells when $k_{air} = 0.9$ for: (a) $ISD = 500m$ (macro Case 1), (b) $ISD = 1732m$ (macro Case 3).

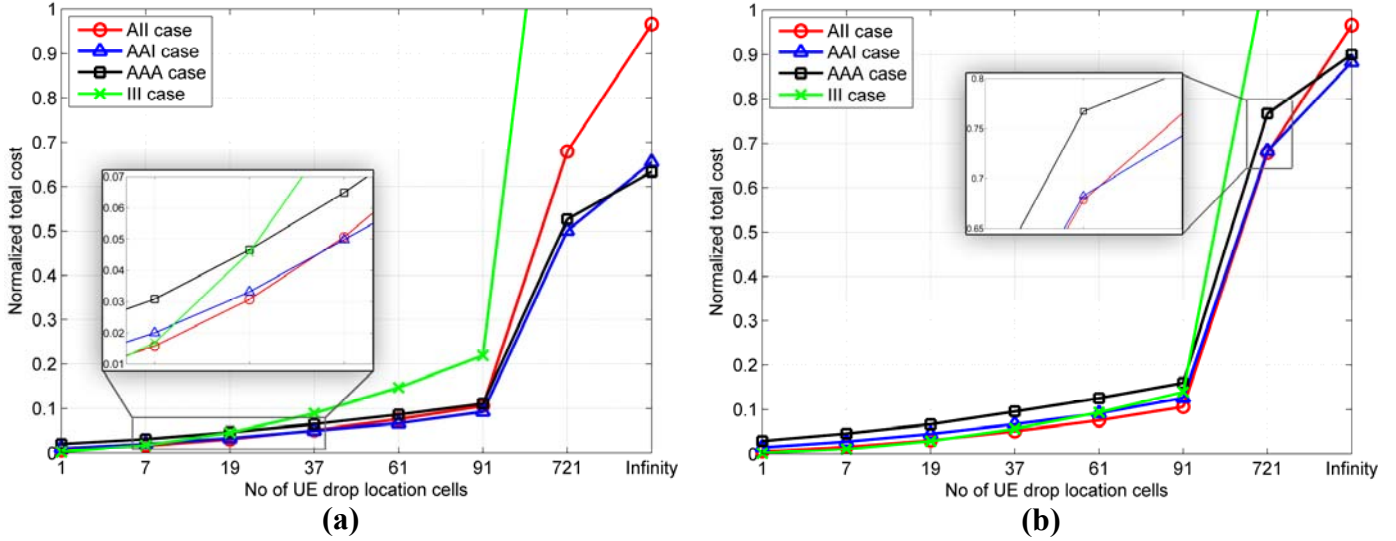

Figure 7. MBSFN cost for AII, AAI, AAA vs. number of UE drop location cells when $k_{air} = 0.8$ for: (a) ISD = 500m (macro Case 1), (b) ISD = 1732m (macro Case 3).

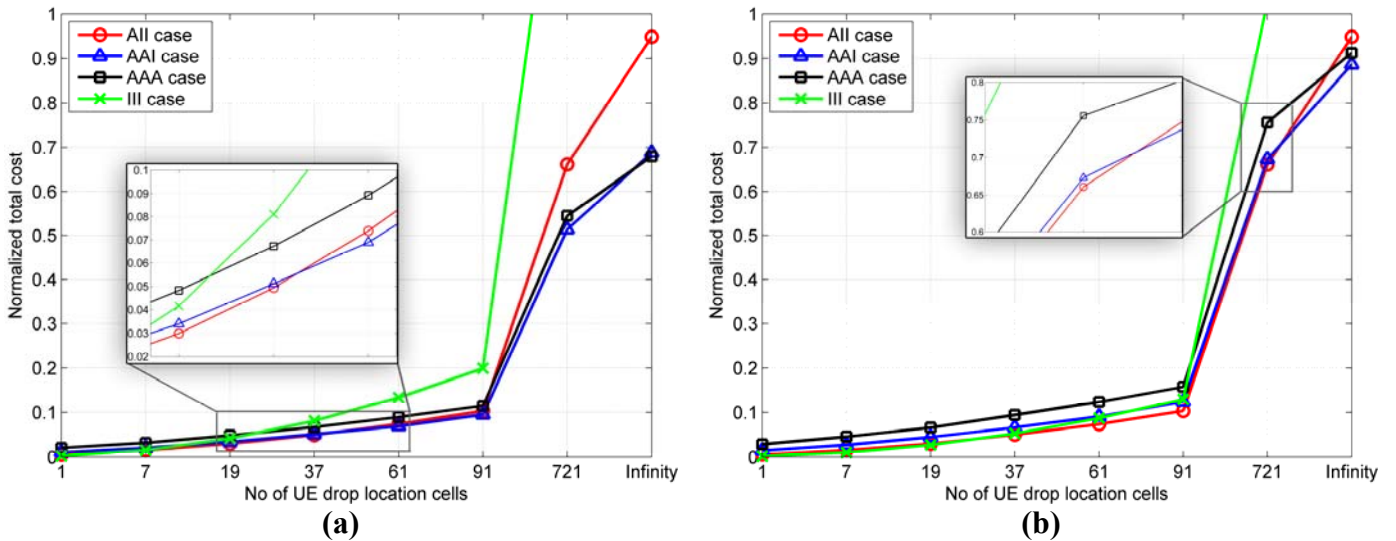

Figure 8. MBSFN cost for AII, AAI, AAA vs. number of UE drop location cells when $k_{air} = 0.7$ for: (a) ISD = 500m (macro Case 1), (b) ISD = 1732m (macro Case 3).

Following the analysis where $k_{air} = 0.9$, similar switching points between the four different MBSFN deployments can be extracted from Figure 7 and Figure 8, where k_{air} is equal to 0.8 and 0.7 respectively. For example from Figure 7(a) ($k_{air} = 0.8$, ISD = 500m) for UE drop location cells 1, 7, 19 AII is the most preferable MBSFN deployment. For UE drop location cells 37, 61, 91 and 721, AAI is preferred, while for the case of infinite UE drop location cells ($>> 721$) AAA is the most efficient MBSFN deployment.

To sum up, Table 2 and Table 3 depict the most preferable MBSFN deployment for the different user distributions and air interface weights in the case of $ISD = 500m$ and $ISD = 1732m$ respectively. More specifically, in both tables the lowest total cost (for each air interface weight) is marked in each column by light green background. The remaining elements in each column show the additional cost percentage that is introduced by using a different MBSFN deployment than the preferable. It may be noted that the number of assisting rings required to minimize the total cost depends on the number of cells occupied by UEs (i.e. the size of the “UE drop location cells” area). In most cases, for small “UE drop location cells” areas AII deployment should be used, for medium “UE drop location cells” areas AAI is the preferable MBSFN deployment, while for very large “UE drop location cells” areas the AAA deployment may decrease the total cost. Finally, III deployment could be used for large ISD and only for very small “UE drop location cells” areas.

Table 2. Preferable MBSFN deployment for $ISD = 500m$.

| | | Number of UE drop location cells | | | | | | | |
|-----------------|-------|----------------------------------|---------|--------|---------|---------|---------|---------|---------|
| k_{air} | Depl. | 1 | 7 | 19 | 37 | 61 | 91 | 721 | Inf |
| $k_{air} = 0.9$ | III | +1.2% | +13.6% | +58.7% | +100.2% | +147.9% | +165.3% | +288.6% | +410.6% |
| | AII | 0.0059 | 0.0162 | 0.0315 | +7% | +20.4% | +20.5% | +42.8% | +67.3% |
| | AAI | +66.1% | +20.4% | +2.5% | 0.0486 | 0.0647 | 0.0902 | 0.4879 | +6.1% |
| | AAA | +230.5% | +83.3% | +42.8% | +28.8% | +28.3% | +18.3% | +4.1% | 0.5875 |
| $k_{air} = 0.8$ | III | +0.1% | +7% | +49.2% | +78.8% | +120.1% | +137.1% | +247% | +334.3% |
| | AII | 0.0057 | 0.0158 | 0.0307 | +1.6% | +13.6% | +14.5% | +35.6% | +52.5% |
| | AAI | +77.2% | +27.2% | +7.8% | 0.0499 | 0.0668 | 0.0925 | 0.5009 | +3.5% |
| | AAA | +252.6% | +94.9% | +51.8% | +30.1% | +29% | +19.7% | +5.1% | 0.6333 |
| $k_{air} = 0.7$ | III | 0.0052 | +3.9% | +39.1% | +64.2% | +94% | +110.1% | +207.5% | +268.1% |
| | AII | +7.7% | 0.0154 | 0.0299 | 0.0494 | +7.3% | +8.6% | +28.7% | +39.7% |
| | AAI | +100% | +33.8% | +13.7% | +3.4% | 0.0689 | 0.0949 | 0.5139 | +1.2% |
| | AAA | +296.2% | +107.8% | +61.5% | +36% | +29.6% | +20.9% | +6.1% | 0.6792 |

Table 3. Preferable MBSFN deployment for $ISD = 1732m$.

| | | Number of UE drop location cells | | | | | | | |
|-----------------|-------|----------------------------------|---------|---------|--------|--------|--------|--------|---------|
| k_{air} | Depl. | 1 | 7 | 19 | 37 | 61 | 91 | 721 | Inf |
| $k_{air} = 0.9$ | III | +1.7% | +3.1% | +6% | +15.4% | +29% | +37.3% | +71.1% | +113.4% |
| | AAI | 0.0060 | 0.0161 | 0.0316 | 0.0527 | 0.0777 | 0.1089 | +0.5% | +11.9% |
| | AAA | +151.7% | +75.2% | +45.6% | +28.8% | +19.2% | +17.5% | 0.6924 | 0.8788 |
| | AAA | +400% | +191.9% | +114.2% | +84.4% | +63.8% | +48.9% | +12.4% | +1% |
| $k_{air} = 0.8$ | III | 0.0056 | +1.3% | +3.2% | +10.7% | +23.6% | +31.7% | +63.1% | +98.3% |
| | AAI | +3.6% | 0.0157 | 0.0308 | 0.0513 | 0.0757 | 0.1060 | 0.6783 | +9.4% |
| | AAA | +164.3% | +77.1% | +47.1% | +30.6% | +21% | +19% | +0.6% | 0.8826 |
| | AAA | +425% | +194.3% | +116.9% | +86.5% | +65.8% | +50.8% | +13.1% | +2% |
| $k_{air} = 0.7$ | III | 0.0048 | 0.0150 | +2.7% | +5.6% | +17.9% | +25.6% | +55.4% | +83.4% |
| | AAI | +18.8% | +2% | 0.0300 | 0.0499 | 0.0737 | 0.1032 | 0.6608 | +7.1% |
| | AAA | +202.1% | +82% | +49% | +32.5% | +22.9% | +20.4% | +1.8% | 0.8864 |
| | AAA | +500% | +202.7% | +120% | +88.8% | +67.8% | +52.9% | +14.4% | +2.9% |

VI. FUTURE WORK

Based on the above estimation, the step that follows this work is to design an algorithm responsible for selecting the most efficient MBSFN deployment scheme for the transmission of the multimedia data, based on the initial user distribution. In this work we assumed that the users either reside in the center cell, or in the first ring around the center cell etc. So we basically suppose that the users can reside in a constantly increasing area consisting of rings. Even though this assumption does not affect the overall evaluation, for the future we plan to examine random user distributions without the restriction of the users residing in certain rings around a center cell.

Another direction that we intent to investigate is the application of Forward Error Correction (FEC) for MBSFN transmissions in LTE networks. FEC is an error control method that can be used to augment or replace other methods for reliable data transmission. The main attribute of FEC schemes is that the

sender adds redundant information in the messages transmitted to the receiver. This information allows the receiver to reconstruct the source data. Such schemes inevitably add a constant overhead in the transmitted data and are computationally expensive. This additional communication cost will be calculated and based on this; the efficiency of FEC use in different scenarios will be evaluated.

VII. CONCLUSIONS

In this manuscript, an analytical approach is proposed to evaluate and validate the performance of a MBSFN LTE network. The proposed evaluation approach is based on the calculation of the total telecommunication cost (including the packet delivery cost and the cost for controlling procedures) of a MBSFN transmission, considering different network topologies, MBSFN deployments and user distributions.

By using this evaluation procedure, we estimate how many neighboring rings of the cells that actually contain users interested in a MBSFN service, should be in the same MBSFN area and thus transmitting in the same frequency, in order to achieve high SFN gains with the lowest possible telecommunication cost. The results have shown that the appropriate MBSFN deployment depends on the geometry and deployment environment of UE drop locations. Finally, for the cases of $ISD = 500m$ and $ISD = 1732m$ we have determined the most preferable MBSFN deployments for different user distributions and air interface configurations.

REFERENCES

- [1] 3GPP TS 25.346, V9.0.0. "Technical Specification Group Radio Access Network; Introduction of the Multimedia Broadcast Multicast Service (MBMS) in the Radio Access Network (RAN); Stage 2 (Release 9)", 2009.
- [2] 3GPP TS 22.146, V9.0.0. "Technical Specification Group Services and System Aspects; Multimedia Broadcast/Multicast Service; Stage 1 (Release 9)", 2008.

- [3] 3GPP TS 36.300, V9.1.0. “Technical Specification Group Radio Access Network; Evolved Universal Terrestrial Radio Access (E-UTRA) and Evolved Universal Terrestrial Radio Access Network (E-UTRAN); Overall description; Stage 2 (Release 9)”, 2009.
- [4] Holma H, Toskala A. “LTE for UMTS – OFDMA and SC-FDMA Based Radio Access”, John Wiley & Sons, 2009.
- [5] 3GPP R1-071049, “Spectral Efficiency comparison of possible MBMS transmission schemes: Additional Results”, 2007.
- [6] 3GPP R1-070051, “Performance of MBMS Transmission Configurations”, 2007.
- [7] 3GPP R1-071433, “Additional Results on EMBMS Transmission Configurations”, 2007.
- [8] Rummler R, Chung Y, Aghvami H. “Modeling and Analysis of an Efficient Multicast Mechanism for UMTS”, IEEE Transactions on Vehicular Technology; 54(1), pp. 350-365, 2005.
- [9] Alexiou A, Bouras C. “Multicast in UMTS: Evaluation and Recommendations”, International Journal of Wireless Communications and Mobile Computing, Wiley InterScience, vol. 8, issue 4, pp. 463-481, 2008.
- [10] 3GPP TS 36.201, V9.0.0. “Technical Specification Group Radio Access Network; Evolved Universal Terrestrial Radio Access (E-UTRA); LTE Physical Layer - General Description (Release 9)”, 2009.
- [11] Ho J, Akyildiz I. “Local anchor scheme for reducing signaling costs in personal communications networks”. IEEE/ACM Transactions on Networking; 4(5): 709-725, 1996.
- [12] Rong L, Ben Haddada O, Elayoubi S. “Analytical Analysis of the Coverage of a MBSFN OFDMA Network”. In Proc. of IEEE Global Communications Conference (IEEE GLOBECOM 2008), New Orleans, LA, USA, November 30 - December 4, 2008.

- [13] Alexiou A, Bouras C, Kokkinos V. "Evaluation of the multicast mode of MBMS". In Proc. of 18th IEEE International Symposium on Personal, Indoor and Mobile Radio Communications, Athens, Greece, September 3-7, 2007.
- [14] Elayoubi S, Ben Haddada O, Fouresti'e B. "Performance evaluation of frequency planning schemes in OFDMA-based networks" IEEE Transactions on Wireless Communications; 7(5): 1623-1633, 2008.
- [15] 3GPP R3-071453, "Comparison of Robust E-MBMS Content Synchronization Protocols", 2007.
- [16] 3GPP R2-062271, "Layer 1 signalling based user detection for LTE MBMS", 2006.

APPENDIX A: ABBREVIATIONS

| Abbreviation | Explanation |
|---------------------|---|
| 3G | 3 rd generation |
| 3GPP | 3 rd Generation Partnership Project |
| 4G | 4 th generation |
| CP | Cyclic Prefix |
| e-BM-SC | evolved Broadcast Multicast Service Center |
| e-MBMS | evolved-Multimedia Broadcast/Multicast Services |
| e-MBMS GW | e-MBMS Gateway |
| e-NB | evolved Node B or base station |
| EPC | Evolved Packet Core |
| e-UTRAN | evolved UTRA Network |
| ISD | Inter Site Distance |
| LTE | Long Term Evolution |
| MAC | Medium Access Control |
| MBMS | Multimedia Broadcast/Multicast Services |
| MBSFN | Multi-Media Broadcast over a Single Frequency Network |
| MCCH | Multicast Control Channel |
| MCE | Multi-cell/multicast Coordination Entity |
| MCH | Multicast Channel |
| MME | Mobility Management Entity |
| MTCH | Multicast Traffic Channel |
| OFDM | Orthogonal Frequency Division Multiplexing |
| PDU | Packet Data Unit |
| PTM | Point to Multipoint |
| PTP | Point to Point |
| RACH | Random Access Channel |
| SC-FDMA | Single Carrier Frequency Division Multiple Access |
| SFN | Single Frequency Network |
| SINR | Signal to Interference-plus-Noise Ratio |
| UE | User Equipment |
| UMTS | Universal Mobile Telecommunications System |
| UTRA | Universal Terrestrial Radio Access |