

Cross-Layer Mechanism for Efficient Video Transmission over Mobile Ad hoc Networks

G. Adam^{1,2}, C. Bouras^{1,2}, A. Gkamas³, V. Kapoulas^{1,2}, G. Kioumourtzis⁴, N. Tavoularis^{1,2}

¹Computer Technology Institute & Press “Diophantus”, Patras, Greece

²Computer Engineering & Informatics Dept, Univ. of Patras, Greece

³University Ecclesiastical Academy of Vella, Ioannina, Greece

⁴Contributing Researcher at Computer Technology Institute & Press “Diophantus”, Patras, Greece

Abstract- Mobile ad hoc networks (MANETs) are becoming more essential to wireless communications due to growing popularity of mobile devices. However, MANETs do not seem to effectively support multimedia applications and especially video transmission. This paper presents a cross-layer mechanism for efficient video transmission over this type of networks. The proposed mechanism consists of a priority-scheduling algorithm, at the network layer, and the use of the IEEE 802.11e standard at the MAC layer. The priority-scheduling algorithm takes into account the frame type of the MPEG-4 video file in order to provide different priorities to the most important video packets. At the MAC layer, the IEEE 802.11e protocol assigns the highest priority to video applications to reduce delay and packets losses due to other competing traffic. This design is easily implemented in any ad hoc wireless network as an extension on the AODV MANET routing protocol. Simulation results conducted with the network simulator ns-2 show the advantages of the proposed design.

I. INTRODUCTION

Mobile Ad hoc NETWORKS (MANETs) are becoming more essential to wireless communications due to growing popularity of mobile devices. A node in MANETs could act as a router while having also the possibility of being the sender or receiver of information. The ability of MANETs to be self-configured and form a mobile mesh network by using wireless links make them very suitable for a number of cases that other type of networks cannot operate. Although, node mobility is a very useful feature for users, it results in a very dynamic topology in which routing can become a very complicated task. An important usage scenario of MANETs could be a disaster area or any kind of emergency, in which the fixed infrastructure has been destroyed or is very limited.

However, one major key issue related to multimedia applications is how to guarantee an acceptable level of Quality of Service (QoS) to the end users. In MANETs, the challenges are even higher due to known limitations of the wireless medium and the frequent link failures, as mobile nodes move independently.

Over the last few years, new protocols were designed and standardized in an effort to increase the transmission rates of the wireless medium. The IEEE 802.11e protocol [1] with QoS enhancements is an international standard that is already implemented in MAC chipsets by a number of vendors. The efforts for the enhancements of the IEEE 802.11 protocol aim

at creating a wireless environment in which, data transmission can be achieved at higher bit rates and longer distances while meeting the QoS criteria posed by applications with delay constraints, like multimedia transmission.

A second major issue in wireless ad hoc networks is related to efficient routing in an environment in which the network topology dynamically changes over time. Over the last years, a sufficient number of routing protocols have been developed by the research community. Each protocol has its own routing strategy and its performance varies depending on network conditions like the density of nodes in a specific area, their speed and direction. Most of these protocols do not take into account the limitations and the special requirements posed by the served applications.

In [2], the effects of various mobility models on the performance of Dynamic Source Routing (DSR) [3] and Ad Hoc On-Demand Distance Vector (AODV) [4] routing protocols are studied. The experimental results illustrate that the performance of a routing protocol varies across different mobility models, node densities and the length of data paths. Another performance evaluation of three widely used MANET routing protocols (Destination-Sequenced Distance Vector DSDV [5], AODV and DSR) with respect to group and entity mobility models is presented in [6]. Simulation results indicate also that the relative ranking of routing protocols may vary, depending on the mobility model.

In [7], a QoS-aware self-configured adaptive framework is presented to provide video-streaming services over MANETs. The routing algorithm periodically updates a set of paths, classifies them according to a set of metrics, and arranges a multipath-forwarding scheme. This proposal operates in a different way under highly dynamic states than under more static situations, seeking to decrease the probability of having broken links and improving the service performance, while using lower signaling overhead.

Matin et al. [8] addresses the use of multi-hop as an alternative to conventional single hop transmission in order to increase the quality of real time video streaming over MANETs. The use of the IEEE 802.11e Enhanced Distributed Channel Access (EDCA) function improves the overall performance of the high priority traffic in MANETs, by using the access control mechanisms of the MAC layer.

In [9], priority assignment mechanisms are considered for implementing priority treatment of packets in a MANET using the DSR routing protocol based on a modified IEEE 802.11 MAC layer operating in the distributed mode. The mechanism includes priority queuing and several methods for providing important messages an advantage in contenting for channel access. In [10] an integrated cross-layer optimization algorithm is proposed in order to maximize the decoded video quality in a multi-hop wireless mesh network with QoS guarantees. Finally, it is investigated in [11] whether or not the operating conditions in a city are likely to permit video streaming. It is found that AODV outperforms DSR over the Manhattan grid model.

In this paper, we focus on improving peer-to-peer communication in MANETs by supporting real-time multimedia transmission. The main idea is to exploit the multimedia coding information from the application layer and use a scheduling policy, so that the most important video packets enjoy the highest priority. At the MAC layer, traffic classes are treated in a different way based on QoS criteria. The proposed cross-layer mechanism introduces some modifications at the procedures of the AODV queuing system. AODV uses a simple First Input First Output (FIFO) queue for all incoming packets from the upper layer. Therefore, all packets are treated with the same way regardless of its importance or delay related constrains.

The applicability of our design can be found in applications with bandwidth, delay and jitter constraints, while keeping at a minimum level the requirements imposed by intermediate stations. The main contribution of this work is the cross-layer mechanism that combines the features of the IEEE 802.11e protocol with a video-based priority-scheduling algorithm. The novelty is also supported by choosing the Manhattan mobility model. Another important contribution is the mixture of network and video-centric metrics in an effort to better assess the video quality at the end user. The simulation results show that the proposed design improves QoS when compared with the performance of the legacy IEEE 802.11e protocol.

The rest of the paper is organized as follows: In the next section, we present the overall architecture of the proposed cross-layer mechanism. Section III discusses the simulation environment and presents the evaluation results. We conclude the paper with notes for future work in Section IV.

II. PROPOSED CROSS-LAYER MECHANISM

In this section, we describe the proposed cross-layer mechanism for video transmission over MANETs. We can distinguish two main areas in which, we prioritize traffic, depending on the importance of the transmitted packets:

- At the network layer, we apply a scheduling policy in which, each incoming packet from the upper layers receives different priority depending on the video frame type.
- At the MAC layer, we differentiate the access of the various applications, based on QoS criteria.

This design (Fig. 1) is based on the attributes of voice and video streaming applications, which are characterized by different tolerance in terms of end-to-end delay. It is obvious that a real time service, like video transmission, requires much less delay than a file transfer application. A way to maximize network performance is to prioritize traffic depending on traffic classes.

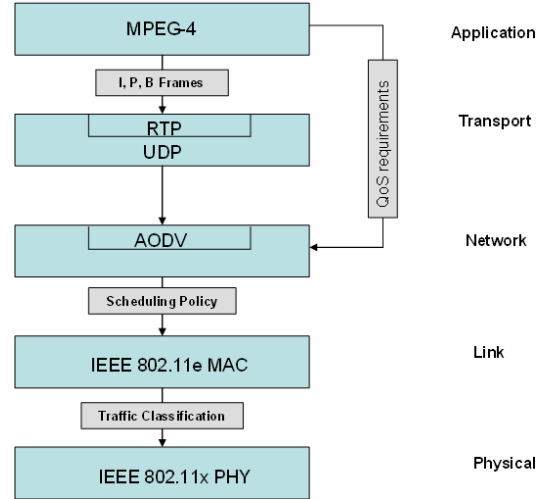

Figure 1. Cross-layer design

That means that a packet with higher priority should be treated completely differently from a packet with low priority in order to be delivered first. In highly loaded MANETs that usually consist of a large number of nodes, or when the bandwidth is limited, there is a significant possibility for the transmitted packets to be dropped from the queues in the mobile nodes.

Priority Scheduling is a popular method for implementing priority queues. Each traffic class has its own queue, in which packets are ordered. This ordering affects directly the way that packets are served and removed from the queue. In the case of a queue that contains video packets the ordering is done by utilizing the frame type information and the assigned priority.

We consider the transmission of video files encoded by a MPEG-4 video encoder that generates three types of video frames. I-frames are the least compressed and contain information from encoding a still image. P-frames are more compressed than I-frames and encoded from the previous I or P-frames. B-frames are the least important in the video sequence and use information from previous and forward frames.

The following algorithm describes the above idea. Instead of using a first-in first-out queue (FIFO) at the MAC layer, we insert the packets in the queue by taking into account the importance of the frame. The most important frames are placed in the top positions in the queue, while other packet types are placed in the tail. The processing of packets is based on the rule that the packet in the head of the queue has to be served first. If the queue exceeds the size limit and needs to drop a packet, then it always drops the one in the tail.

```

enqueue(packet) {
  if(packet.isVideo()) {
    while(nextPacket.isVideo() AND nextPacket.priority <
packet.priority) {
      position=position+1;
    }
    insertToQueue(packete, position)
  } else {
    insertToQueue(packete, tail)
  }
  if(queue.size() > limit) {
    dropTail()
  }
}

```

Algorithm 1. Enqueue function

The IP datagrams are also marked based on the underlying application type. This is a simpler task in mesh networks than in wired with fixed infrastructure, in which different administrative domains may exist in a path between video sender and receiver(s). Ad hoc networks provide this flexibility as every node in the network acts also as router. The main function for providing QoS support in IEEE 802.11e protocol is the Enhanced Distributed Coordination Function (EDCF). This function is responsible for managing the wireless medium in the Contention Period (CP) and enhances the Distributed Coordination Function (DCF) function of the legacy IEEE 802.11 protocol. Therefore, we implement four different data Traffic Classes (TCs) and video traffic is assigned with the highest priority amongst other applications that operate in the wireless network.

III. PERFORMANCE EVALUATION

Most of the related work has been evaluated through simulations conducted with the ns-2 [12] network simulator. These evaluations are mainly based on “classic” network metrics (throughput, delay, packet losses, etc). Our evaluation combines both network and media-centric metrics. For the purpose of this work, we use the Peak Signal to Noise Ratio (PSNR) to assess the quality of the received video file at the end user. PSNR is a derivative of Signal to Noise Ratio (SNR) and computes the maximum possible signal energy to the noise energy, which results in a higher correlation with the subjective quality perception than the conventional SNR.

Equation (1) gives the definition of the PSNR of a source image s and destination image d [13]:

$$PSNR(s, d) = 20 \log \frac{V_{peak}}{MSE(s, d)} \text{ in dB}$$

where

$$V_{peak} = 2^k - 1, k \text{ bit color depth}$$

$$MSE(s, d) = \text{mean square error of } s \text{ and } d$$

In order to conduct a number of realistic experiments with real video files, we use the Evalvid [14] tool-set in conjunction with ns-2. For our simulations, we use a YUV raw video, which consists of 7319 frames and has duration of 365 seconds. The network topology simulates the Manhattan grid mobility model, which is based on the Manhattan city model

with uniform sized building blocks. The Manhattan grid mobility model can be considered as an ideal model to represent the conditions of a big city. The simulation area is 2000x2000 meters in a 4x4 grid. Inside this area, there are 300 mobile nodes representing moving vehicles that are actually the transmitters and receivers of the video file. The moving speed varies from 0 to 20m/sec, having a mean value of 15m/sec. The video transmission is based on the Real-time Transport Protocol (RTP) [15] that is designed for audio and video delivery over IP networks. Table I summarizes the simulation parameters.

TABLE I
SIMULATION PARAMETERS

Routing Protocols	AODV
Mobility model	Manhattan Grid Model
Simulation duration	365 seconds
Number of nodes	300
Simulation area	2000 x 2000m
Node speed	0 – 20 m/sec (random)
MAC	802.11e

In order to evaluate the performance of our mechanism we perform two simulation scenarios. The first scenario focuses on the performance evaluation of the scheduling algorithm without any background traffic in order to verify the “enhance protection” to the most important I-frames. The second evaluation scenario focuses on the performance of the scheduling algorithm with background traffic in order to evaluate the implemented priority queue to high priority video packets.

A. Performance of the Scheduling Algorithm without any background traffic

In this simulation, it is assumed that there is only one active video transmission in the network, without any other data traffic. Thus, transmitted packets are either video or routing packets. We run two different simulation scenarios, with 802.11g and 802.11e protocols, respectively. The aim of this simulation it to evaluate the mechanism which provides enhance protection to I-frames. The comparison shows how the adaptation on the packet queues affects video transmission.

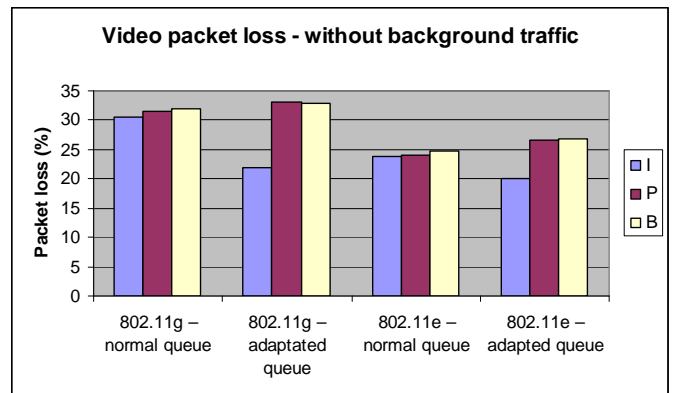

Figure 2. Video frame loss without background traffic

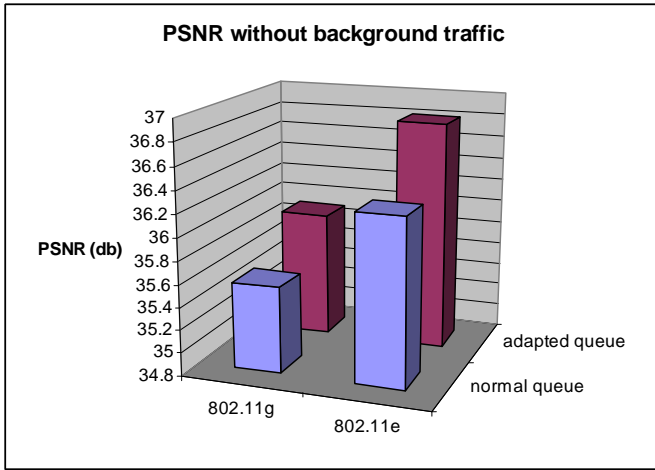

Figure 3. PSNR without background traffic

TABLE II
SIMULATION RESULTS WITHOUT BACKGROUND TRAFFIC

	802.11g	802.11e
Overall packet delivery ratio	69.7%	75.2%
Average end to end delay (all packets)	499ms	343ms

As Fig. 2 indicates, the implemented adapted queue results to a significant reduction of the losses of I-frames, at the cost of a slight increase of P and B-frame losses. In contrast, packet losses remain almost the same for every type of video packets when using the normal FIFO queue.

The metrics for overall packet losses and end-to-end delay are mostly related to the network conditions and are not affected by the adaptations of the scheduling mechanism for video packets. In addition, when using the 802.11e protocol, the routing packets are transmitted with the highest priority improving the AODV performance. Apart from the above network metrics, we use PSNR to evaluate the efficiency of the proposed mechanism. Fig. 3 shows that the implemented adapted queue leads to a significant improvement of PSNR measurements both on the 802.11g and 802.11e networks. As expected, the 802.11e network provides better results compared to 802.11g due to 802.11e QoS features. All the above improvements increase the end user experience.

B. Performance of the Scheduling Algorithm with background traffic

In this scenario, we use the same video transmission with the previous simulation. However, this time there are 20 TCP connections in the network. The amount of data that each node transfers during the simulation lifetime is about 910 kilobytes. In addition, we run two different simulation scenarios with 802.11g and 802.11e networks, respectively. Our objective is to evaluate the implemented priority queue which provides high priority to video packets. The packet types in this case are falling under the following categories; routing, video and background data packets.

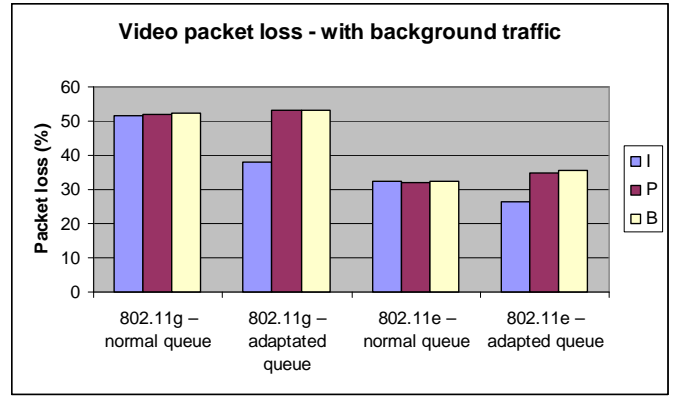

Figure 4. Video frame loss with background traffic

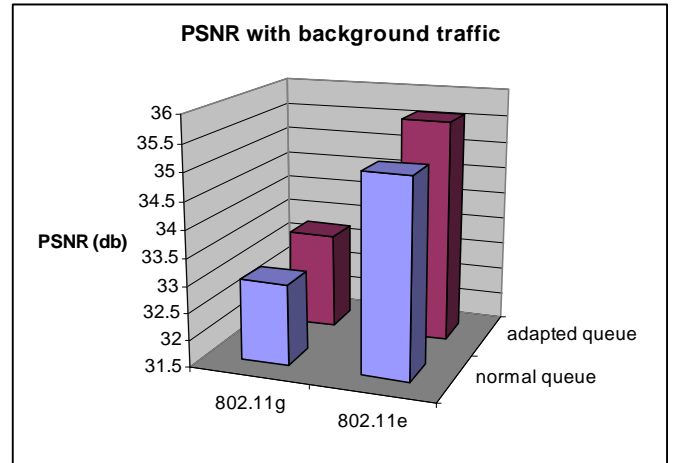

Figure 5. PSNR with background traffic

TABLE III
SIMULATION RESULTS WITH BACKGROUND TRAFFIC

	802.11g	802.11e
Overall packet delivery ratio	80.8%	89.8%
Average end to end delay (all packets)	351ms	217ms

According to Fig. 4, the losses of video frames have been increased in contrast to the overall packet losses. This behavior can be explained if we consider the amount of the transmitted background (about 50000) and video packets (about 13000). In addition, the size of the video packet is much greater than the size of all other packets that have been transmitted. As a result, the possibility of transmission failure of a video packet is much greater than in any other packet. However, the background traffic packet delivery ratio has greater effect on the overall ratio.

In this simulation, the implemented adapted queue prioritizes the video packets and we notice an important improvement in the loss ratio of I-frames (the improvement is multiple compared to the previous simulation scenario without background traffic). The cost we pay for the improved packet loss ratio of I-frames is the increase of P and B-frame packet loss. However, this cost is not very important when comparing with the benefit of better packet delivery ratio of I-frames.

Fig. 5 shows that the implemented adapted queue leads to a significant improvement of PSNR measurements both in 802.11g and 802.11e networks. It is important to mention that the resulting end user experience does not deteriorate by the background traffic as indicated by the PSNR values.

Finally, we show the impact of traffic prioritization to the reception rate. The cases of adaptations on the queuing system are omitted since any changes to the scheduling policy do not affect the real transmission rate.

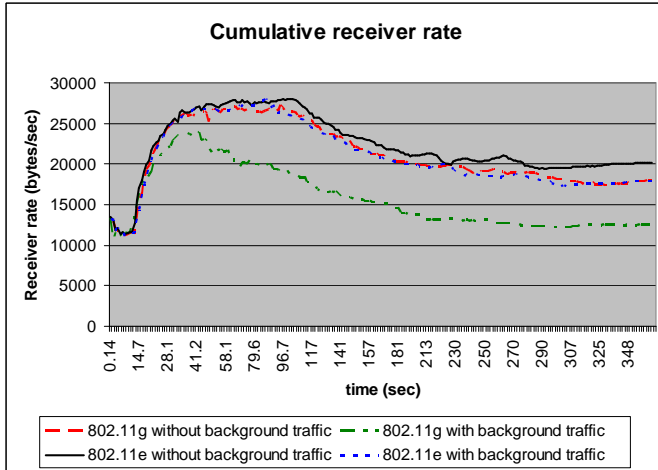

Figure 6. Cumulative receiver rate for video transmission

The utilization of 802.11e traffic classes is extremely efficient (Fig 6). The reception rate of 802.11e scenario with background traffic reaches the rate of a transmission using 802.11g protocol without any background traffic.

IV. CONCLUSIONS AND FUTURE WORK

In this paper, we focused on improving video transmission over MANETs. The main idea was to exploit the multimedia coding information from the application layer in order to use a scheduling policy at the network layer so that the most important video packets could enjoy the highest priority. In order to evaluate the performance of the proposed cross-layer mechanism we conducted a number of simulations with the network simulator ns-2. Our findings were very encouraging and indicated the efficient operation of the adapted queue on providing high priority to video packets.

The utilization of the 802.11e Traffic Classes (TCs) was proved very efficient in environments in which video transmission competed for network resources with background TCP traffic. The easiness of setting and utilizing the 802.11e QoS features to MANETs in which all nodes act as routers made that protocol an indispensable network feature of any MANET implementation.

Our future work includes the comparison of the proposed design with other priority schemes for MANETs and the evaluation of the proposed mechanism under more complicated MANETs and simulation scenarios. Another important area which left for future work is to include the transport layer in the cross-layer design in an effort to adapt the video transmission rates based on the network conditions. We believe that this will further increase the QoS that is finally offered to the end user.

REFERENCES

- [1] IEEE 802.11 WG, Part 11: "Wireless LAN Medium Access Control (MAC) and Physical Layer (PHY) specifications Amendment 8: Medium Access Control (MAC) Quality of Service Enhancements".
- [2] V. Timcenko, M. Stojanovic and S.B. Rakas, "MANET routing protocols vs. mobility models: performance analysis and comparison", Proceedings of the 9th WSEAS international conference on Applied informatics and communications, p. 271-276, 2009.
- [3] D. Johnson, Y. Hu and D. Maltz, The Dynamic Source Routing Protocol (DSR) for Mobile Ad Hoc Networks for IPv4, RFC 4728, February 2007.
- [4] C. Perkins and E. Belding-Royer, Ad hoc On-Demand Distance Vector (AODV) Routing, RFC 3561, July 2003.
- [5] C. E. Perkins and P. Bhagwat "Highly Dynamic Destination- Sequenced Distance-Vector Routing (DSDV) for Mobile Computers," Computer Communications Review, pp. 234-244, October 1994.
- [6] B. Divecha, A. Abraham, C. Grosan and S. Sanya, "Impact of Node Mobility on MANET Routing Protocols Models", Journal of Digital Information Management, 2007.
- [7] M. A. Igartua and V. C. Frías, "Self-configured multipath routing using path lifetime for video-streaming services over Ad Hoc networks", Computer Communications 2010, Volume 33, Issue 15, pp. 1879-1891, 2010.
- [8] M. Matin and N. Naaji, "Performance Analysis with Enhanced Distributed Channel Access (EDCA) in IEEE 802.11e for Real Time Video Streaming (MPEG-4) in Multi-hop MANET", Journal of Communication and Computer. Vol. 7, no. 4, pp. 24-29, April 2010.
- [9] X. Pallot and L. E. Miller, "Implementing message priority policies over an 802.11 based mobile ad hoc network", IEEE Military Communications Conf. (MILCOM), pp. 860 - 864, 2001.
- [10] Y. Andreopoulos, N. Mastrorade and M. van der Schaar, "Cross-Layer Optimized Video Streaming Over Wireless Multihop Mesh Networks", Selected Areas in Communications, IEEE Journal on Selected Areas in Communications, IEEE Journal on, Vol. 24, No. 11, pp. 2104-2115, 2006.
- [11] N. Qadri, M. Altaf, M. Fleury, M. Ghanbari and H. Sammak, "Robust Video Streaming over an Urban VANET", IEEE International Conference on Wireless and Mobile Computing, Networking and Communications, pp.429-434, 2009.
- [12] The UCB/LBNL network simulator, software online: <http://www.isi.edu/nsnam/ns/>
- [13] J. Cavers, "Mobile Channel Characteristics", Kluwer Academic, 2000.
- [14] J. Klauke, B. Rathke and A. Wolisz, "EvalVid – A Framework for Video Transmission and Quality Evaluation", Proceedings of the 13th International Conference on Modeling, Techniques and Tools for Computer Performance Evaluation, Urbana, Illinois, 2003.
- [15] H., Casner, S., Frederick and R., Jacobson, RFC 3550: "RTP: A transport protocol for real-time applications", Schulzrinne, V. (eds.), July 2003.